

EISEN PART NUMBER	GM PART NUMBER	FORD PART NUMBER	FINISH	L(length) mm
				NOM
805077-08	11546966	W507120	GMW16730 BLACK	8
805077-10	11611112	W507121	GMW4205 BLACK	10
805077-12	11546968	W507122	GMW16730 BLACK	12
805077-14	11546969	W507123	GMW16730 BLACK	14
805077-16	11546970	W507124	GMW16730 BLACK	16
805077-20		W507125	GMW16730 BLACK	20
805077-25		W507126	GMW16730 BLACK	25
805077-30		W507127	GMW16730 BLACK	30
805077-35		W507128	GMW16730 BLACK	35

REVISIONS					
ZONE	REV.	DATE	DESCRIPTION	DRW	APR
	1	20140325	RELEASE FOR REVIEW	CS	LK
	2	20150107	ADDED FORD PART NUMBERS TO TABLE	CS	LK

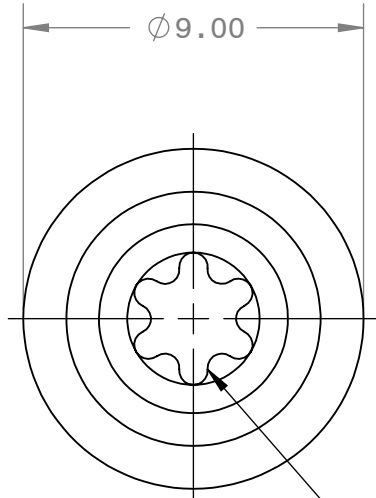

T-20 RECESS

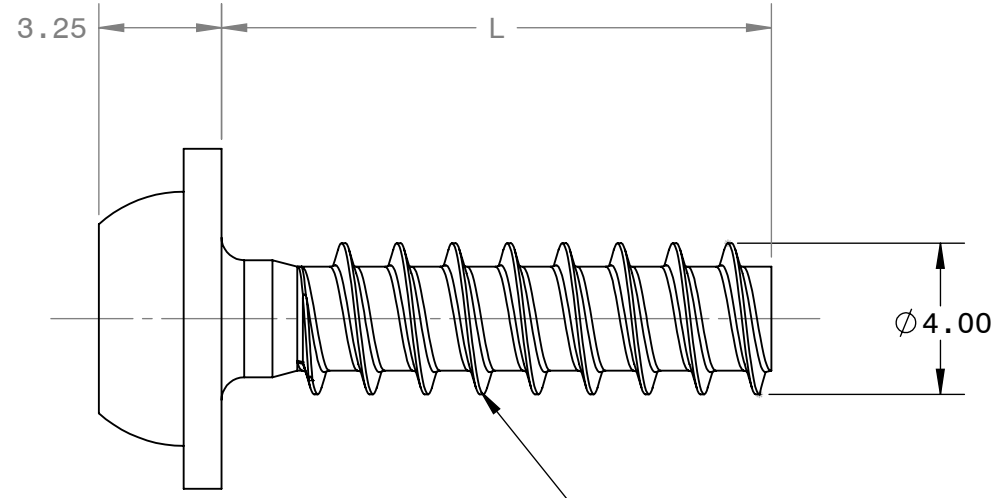

4.0 TP30 THREAD

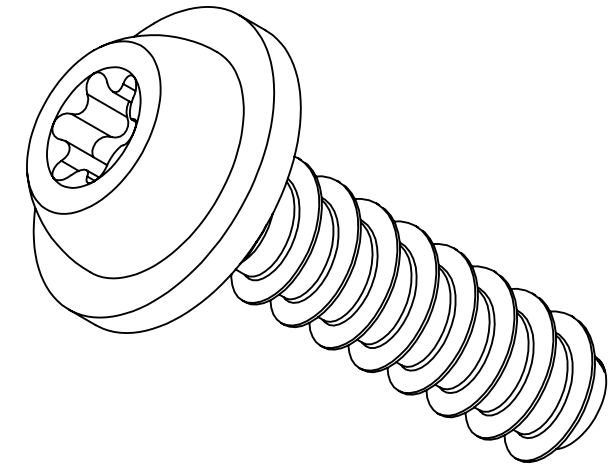

NOTES:

1. THREAD FORMING SCREW FOR PLASTIC
2. MATERIAL STEEL HEAT TREATED

CUSTOMER DRAWING

CONFIDENTIAL

	NAME	DATE	 LANSING, MICHIGAN 48911
DRAWN	CS	20141110	
CHECKED			
ENG APPR.	LK	20141110	
MFG APPR.	LK	20141110	
Q.A.			TITLE:
PROPRIETARY AND CONFIDENTIAL THE INFORMATION CONTAINED IN THIS DRAWING IS THE SOLE PROPERTY OF EISEN ELECTRIC CORP. ANY REPRODUCTION IN PART OR AS A WHOLE WITHOUT THE WRITTEN PERMISSION OF EISEN ELECTRIC CORP. IS PROHIBITED.			SCREW 4.0 TP30 THR PAN FLANGE HEAD 9.0 T20
SIZE	DWG. NO.	REV	
B	805077-XX	02	
SCALE: 5:1		SHEET 1 OF 1	